



SUBMITTAL DRAWING
AMI - 50 CRD
CEILING RADIATION DAMPERS
(SQUARE AND RECTANGULAR)

STANDARD CONSTRUCTION

MAXIMUM SIZE
24" x 24"

MINIMUM SIZE
4" x 4"

FUSIBLE LINKS
165 deg, Standard

FINISH
Mill

UL Classified
1 1/2 Hour Rating

FRAME
22 ga. Rollformed galvanized steel

BLADES
22 ga. Galvanized steel

- Note:
1. Manufactured with Blade opening as per Sketch #1 when 'W' is equal to or greater than 6".
 2. Manufactured with Blade opening as per Sketch #2 when 'W' is less than 6" or 'H' is greater than 'W' .
 3. Ceramic Insulation is not UL required on Dampers with areas less than 80 sq. in. and is optional. Dampers above 80 sq. in. will be provided with Blade Insulation.

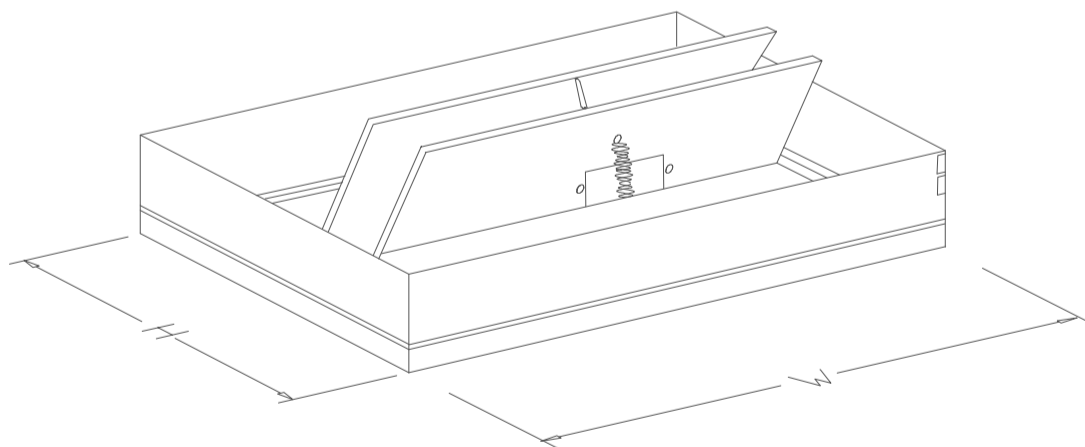
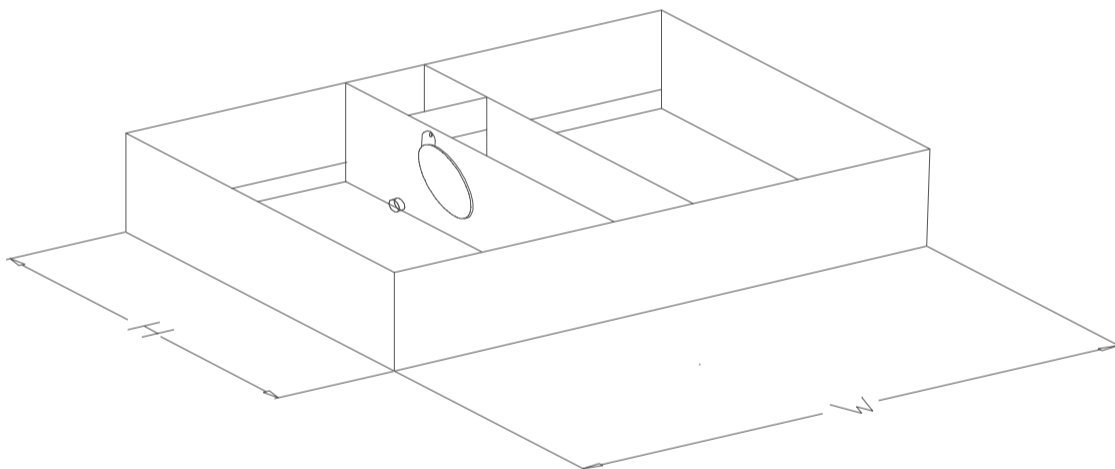
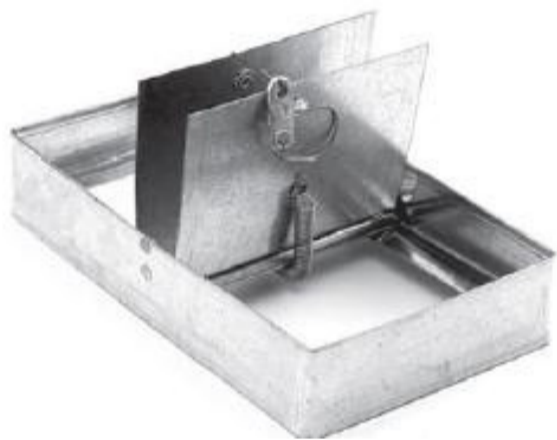

UNDERWRITERS LABORATORIES (UL555)
CLASSIFIED FIRE DAMPERS
FIRE RESISTANCE RATED 3 HOURS.
FOR USE IN UL CLASSIFIED BUILDING
MATERIALS RATED 4 HOURS OR LESS.

Project:

Contractor:

Location:

Address:

Architect

P.O. Number:

Engineer:

Date: