



SUBMITTAL DRAWING
AMI- 75 CRHGC
GARBAGE CHUTE

STANDARD CONSTRUCTION

TYPE
CRHGC

MAXIMUM SIZE

Single section -28" DIA

FRAME

22 ga. Rollformed Steel frame

MINIMUM SIZE

18" DIA.

COLLAR

20 guage

FINISH

Mill

BLADES

22 ga. Interlocking Steel Blades
 'Out of the Air Stream'

Fusible Link.

165 deg. F Standard

OPTIONS:

- 304 Stainless Steel Construction
- 212 deg. F. Fusible Link
- Without Collar
- With Collar

U.L. Classified
1-1/2 Hour Rating

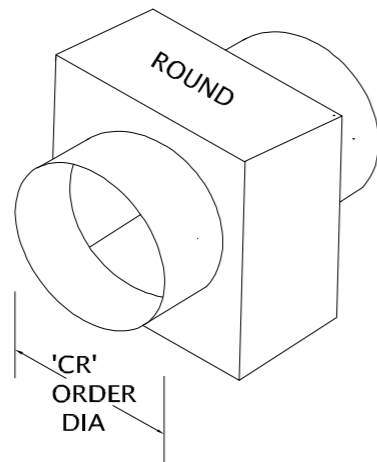

(H) HORIZONTAL MOUNT

Horizontal mounting model includes stainless steel negator spring and blade locks

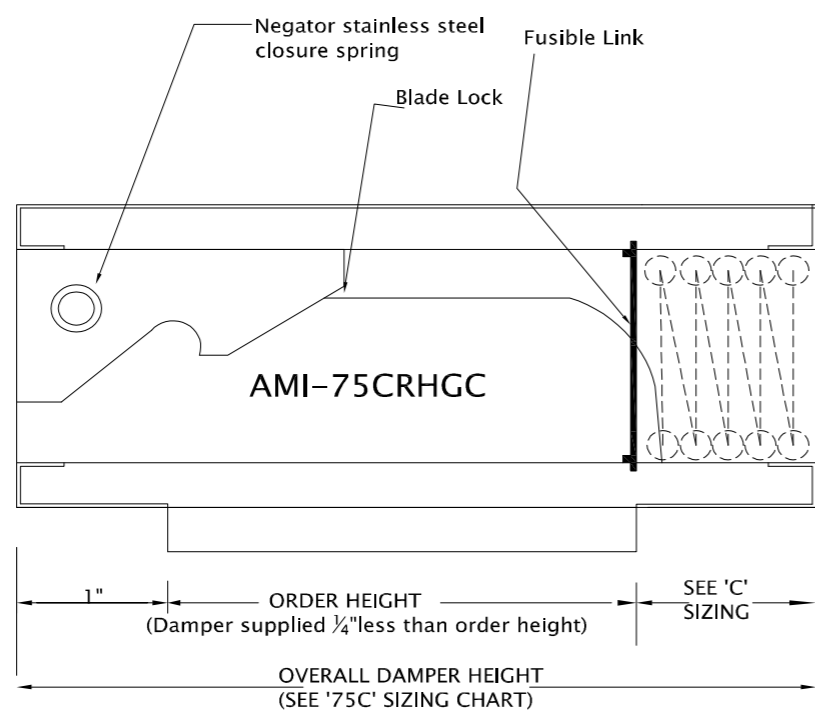
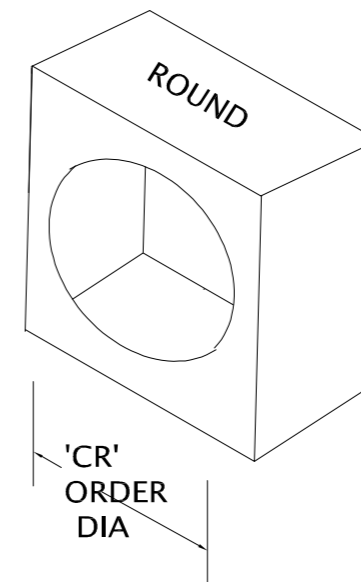

(H) HORIZONTAL MOUNT

HORIZONTAL MOUNTING MODEL INCLUDES STAINLESS STEEL NEGATOR SPRINGS AND BLADE LOCKS

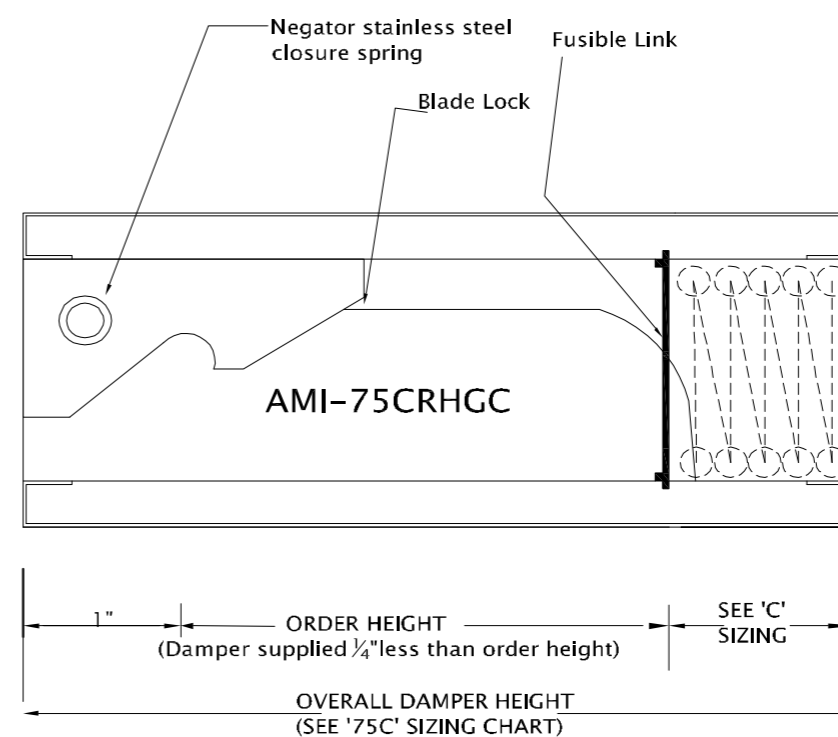

(H) HORIZONTAL MOUNT

HORIZONTAL MOUNTING MODEL INCLUDES STAINLESS STEEL NEGATOR SPRINGS AND BLADE LOCKS

Project:

Contractor:

Location:

Address:

Architect

P.O. Number:

Engineer:

Date: