

1) INSTALLATION AND MAINTENANCE INSTRUCTIONS – 1-1/2 HOUR RATED, UL CLASSIFIED FIRE DAMPER FOR USE IN FIRE BARRIERS WITH RATINGS LESS THAN 2 HOURS.

INSPECTION

- Inspect for shipping damage.
- Inspect for proper size and model.
- Inspect installed damper for proper orientation, as stated on damper label.
- Inspect for obstructions which could interfere with free operation and complete closure.
- Manually cycle the damper to verify proper operation.

INSTALLATION

The basic intent of a proper installation is to secure the fire damper in, not to, the opening in such a manner as to prevent distortion and disruption of the damper operation by allowing the fire damper in openings to expand and the connecting duct to separate in the event of the collapse of the hanging system. The fire damper must be positioned within the plane of a UL approved fire partition. These partitions are: concrete floors, masonry walls or partitions framed with steel or wood studs and gypsum wallboard. Reference page 2 for details of a suggested drywall partition.

DAMPER TO SLEEVE ATTACHMENT

Sleeves shall be used of sufficient length to permit direct attachment of perimeter mounting angles. This damper can be supplied by the factory mounted in a sleeve. If the sleeve is not factory supplied, it must be attached on both sides of the damper by one of the following methods:
Secure with 1/4" dia. bolts and nuts or by welding with beads 1/2" in length, or with No. 10 steel sheet metal screws, or 3/16" steel rivets. Fasteners shall be 6" maximum on centers. Fasteners cannot be placed where they will interfere with damper operation. Gaps at corners between the damper and its sleeve must be small enough to prohibit the passage of an 1/8" diameter rod through the entire depth of the gap between two damper panels and its sleeve.

EXPANSION CLEARANCE

- The opening in the wall or floor for the fire damper shall be sized so as to provide expansion clearance between the sleeve and opening. Clearances do not vary with walls constructed of different materials. A minimum of 1/8" per foot of overall damper/sleeve width and height is required. The maximum opening size shall not exceed 1/8" per foot plus 1", minimum total clearance shall be at least 1/4" larger than the overall assembly.

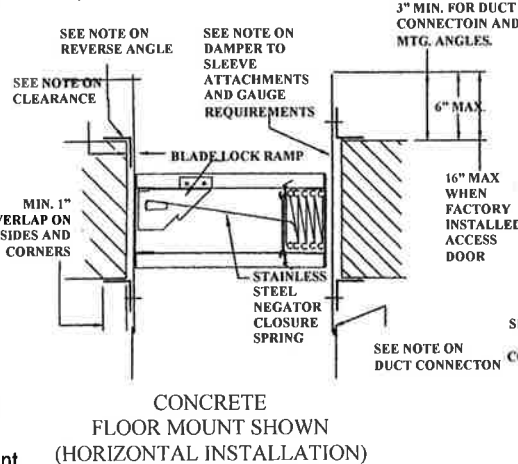

CONCRETE FLOOR MOUNT SHOWN (HORIZONTAL INSTALLATION)

SLEEVE THICKNESS

Sleeves shall be the same gauge or heavier as the duct to which it is attached. Gauges shall conform to SMACNA or ASHRAE duct standards

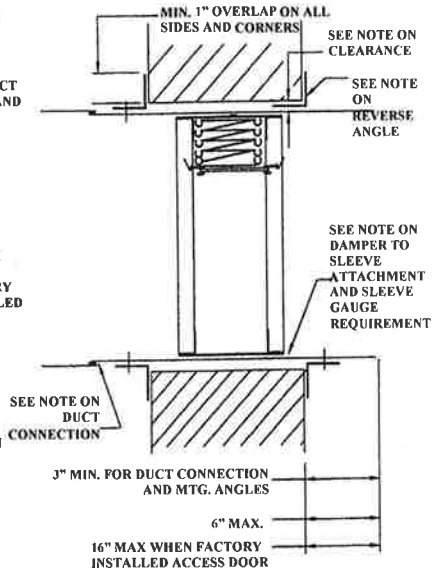

WALL MOUNT SHOWN (VERTICAL INSTALLATION)

2) INSTALLATION AND MAINTENANCE INSTRUCTIONS – 2 HOUR RATED, UL CLASSIFIED FIRE DAMPER FOR USE IN FIRE BARRIERS WITH RATINGS LESS THAN 2 HOURS.

INSPECTION

- Inspect for shipping damage.
- Inspect for proper size and model.
- Inspect installed damper for proper orientation, as stated on damper label.
- Inspect for obstructions which could interfere with free operation and complete closure.
- Manually cycle the damper to verify proper operation.

INSTALLATION

The basic intent of a proper installation is to secure the fire damper in, not to, the opening in such a manner as to prevent distortion and disruption of the damper operation by allowing the fire damper in openings to expand and the connecting duct to separate in the event of the collapse of the hanging system. The fire damper must be positioned within the masonry or block fire barrier.

DAMPER TO SLEEVE ATTACHMENT

Sleeves shall be used of sufficient length to permit direct attachment of perimeter mounting angles. This damper can be supplied by the factory mounted in a sleeve. If the sleeve is not factory supplied, it must be attached on both sides of the damper by one of the following methods:
Secure with 1/4" dia. bolts and nuts or by welding with beads 1/2" in length, or with No. 10 steel sheet metal screws, or 3/16" steel rivets. Fasteners shall be 6" maximum on centers. Fasteners cannot be placed where they will interfere with damper operation. Gaps at corners between the damper and its sleeve must be small enough to prohibit the passage of an 1/8" diameter rod through the entire depth of the gap between two damper panels and its sleeve.

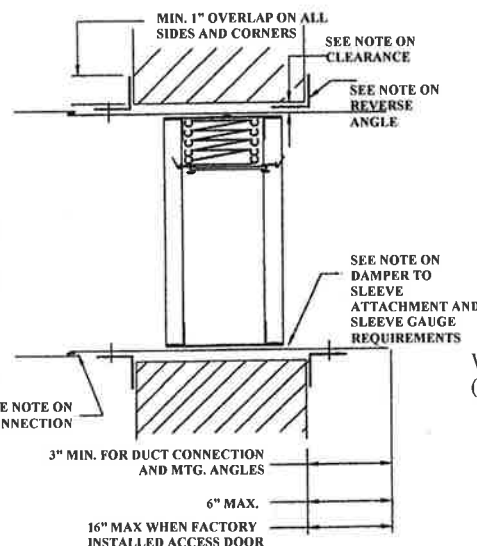

WALL MOUNT SHOWN (VERTICAL INSTALLATION)

SLEEVE THICKNESS

Sleeves shall be the same gauge or heavier as the duct to which it is attached. Gauges shall conform to SMACNA or ASHRAE duct standards.

EXPANSION CLEARANCE

The opening in the wall or floor for the fire damper shall be sized so as to provide expansion clearance between the sleeve and opening. Clearances do not vary with walls constructed of different materials. A minimum of 1/8" per foot of overall damper/sleeve width and height is required. The maximum opening size shall not exceed 1/8" per foot plus 1", minimum total clearance shall be at least 1/4" larger than the overall assembly.



See complete marking on product

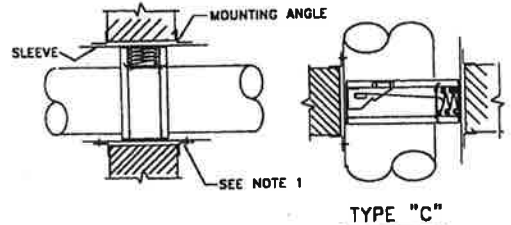
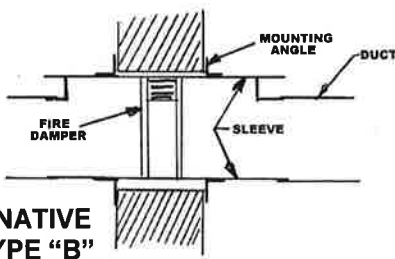
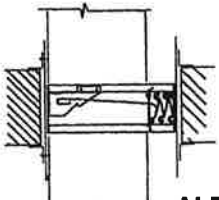
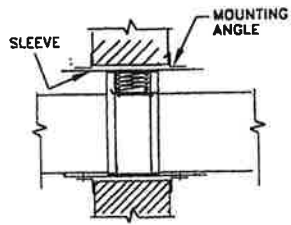

ALTERNATIVE TYPE "B" MOUNTING

TYPE "C"

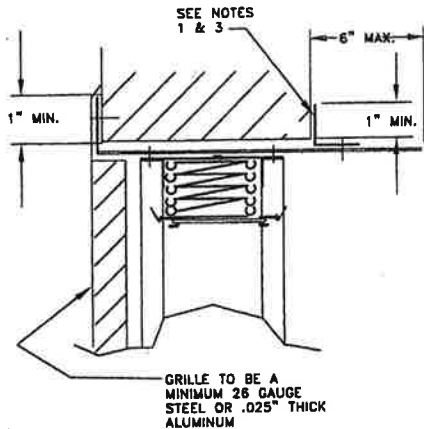

DAMPER BEHIND A GRILLE

1. Perimeter mounting angles to be 1-1/2 x 1-1/2 x 16 ga.
2. Grille to flange fasteners cannot penetrate fire wall (see note 4).
3. Secure angles to sleeve only, so as to frame the wall opening. Fasten to the sleeve only using the same means as required for fastening the damper to the sleeve.
4. Grille to flange attachment by means of 1/4" dia. pop rivets, #8 sheet metal screws or #8 bolts and nuts. Fasteners to be plated steel or stainless steel, minimum two fasteners per side.

The factory supplied 22 ga. collar to 18 ga. cap connection on type "C" dampers is a breakaway connection under the following conditions:

1. Round unit duct diameters are no larger than 36"
2. Oval duct sizes are no larger than 36" W x 29"H.
3. Duct gauges shall conform to the SMACNA or ASHRAE duct standard.
4. Duct diameters of 22 inches (559 mm) and smaller shall have three (3) No. 10 (4.8 mm) diameter sheet metal screws evenly spaced around the circumference of the duct.
5. Duct diameters from 22 inches to 36 inches shall have five (5) sheet metal screws evenly spaced around the circumference of the duct.
6. Dampers outside of these restrictions (i.e.) multiple dampers and special size and application dampers must use a 4" wide drawband connection as shown in the SMACNA Fire, Smoke, and Radiation Damper Installation Guide.

3) INSTALLATION INSTRUCTIONS FOR 1-1/2 HOUR RATED UL CLASSIFIED FIRE DAMPERS INSTALLED INTO METAL OR WOOD FRAMED 1 & 2 HOUR RATED DRYWALL PARTITIONS

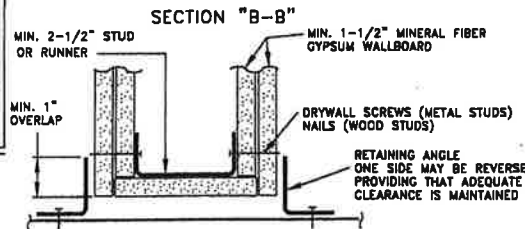
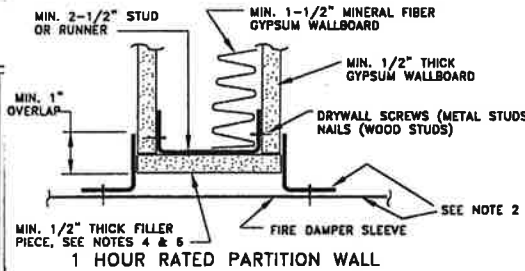
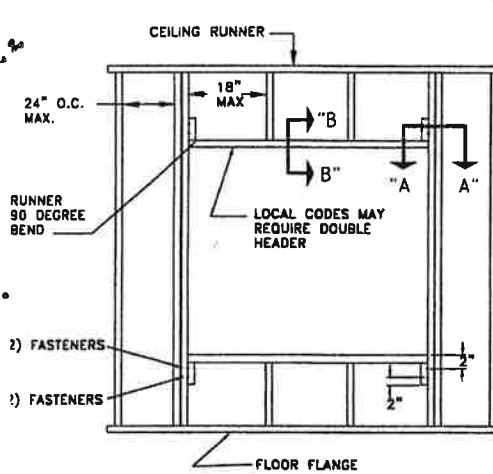

NOTES:

1. These illustrated partition designs have successfully been tested in conjunction with 1-1/2 hour classified fire dampers, for additional designs, reference Underwriters Laboratories, Inc. Fire Resistance Directory. Specific framing requirements of openings may vary with the local authority that has jurisdiction. Specific framing requirements should be provided in the architectural and structural drawings.
2. Reference the damper's installation instructions regarding the approved method of attaching the damper to the sleeve, attaching the retaining angles to the sleeve, required expansion clearances, sleeve gauge, etc. Type of framing does not effect the stated required expansion clearance.
3. Gypsum panels surrounding the opening are to be fastened to all stud and runner flanges, 12" O.C. maximum.
4. When wooden studs are used, filler pieces must be installed around the entire opening. Filler pieces are optional when metal studs are used (consult local codes to determine if filler pieces are required). Filler pieces are to be double screwed (or nailed to wooden studs) on 12" max. centers to the web of runners and studs.
5. The Office of the California State Fire Marshal and other local jurisdictions require filler pieces around both wood and metal framed openings (no filler pieces around concrete or masonry openings). These codes also require a double header for wood framed openings, consult local code authorities.
6. Double jamb studding shown and required when opening width or height exceeds 36". Single jamb studding acceptable for openings 36" x 36" and smaller.

MOUNTING ANGLES

Secure the 4 separate (per side) mounting angles to the sleeve and not to the wall or floor. Mounting angles shall frame the four sides of the sleeve on both faces. When reverse mounting angles are used the size of the opening must be increased to maintain the specified expansion clearance between the angle / fasteners and the opening. Angles shall be 1-1/2" x 1-1/2" x 16ga. Fasten angles to the sleeve using 1/4" dia. bolts and nuts or by welding with beads 1/2" in length, or with No. 10 steel sheet metal screws, or with 3/16" steel rivets. Fasteners or weld beads shall be 6" maximum on centers. Angles are not to be secured together at corners.

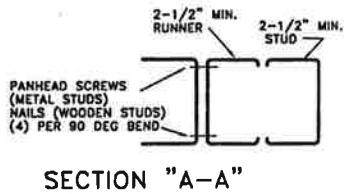

ACCESS

Suitable access must be provided for damper inspection and servicing. Where it is not possible to achieve sufficient size access, it will be necessary to install a removable section of duct.

CAULKING

Caulking is allowed between the mounting angles and the damper sleeve, and between the mounting angles and the floor or wall construction. Caulking is not allowed between the damper sleeve and the wall or floor inside the opening. Caulk shall be one of the following: Dow Corning RTV 732, or RTV 108 by GE.

DUCT CONNECTION – SEE BREAKAWAY CONNECTION DIAGRAM

The installation of the damper and all duct connections to the damper sleeve shall conform to NFPA-90A and the SMACNA Fire, Smoke and Radiation Damper Installation Guide. All duct connections shall also conform to UL555. Connecting ducts shall not be continuous but shall terminate at the damper sleeve. Duct connections to the sleeve will be either of the breakaway or rigid types, breakaway types are listed below. The following determines if the connections are to be rigid or breakaway. For rigid type duct connections, sleeve shall be a minimum of 16 ga. on dampers not exceeding 36" wide or 24" high or 24" diameter and 14 ga. on larger units. Dampers supplied with thinner sleeves will require a breakaway connection of the following type. Plain "S" slip, double "S" slip shown below. Ductmate type-connections as shown below. All connections not listed as breakaway shall be considered as rigid. Breakaway joints of the types shown below shall have no more than two No. 10 (4.8 mm) diameter sheet metal screws on each side and on the top and bottom located in the center of the slip pocket and shall penetrate both sides of the slip pocket. Breakaway joints of the type shown below are permitted on the top and bottom of horizontal ducts (vertical dampers) with flat slips not exceeding 20 inches (508 mm) in length on the sides.

MAINTENANCE

Dampers shall be maintained in intervals as stated in NFPA-90A, Appendix B, unless local codes require more frequent inspections. Check the fuse link, check the stainless steel closure springs where furnished, cycle damper and check for free operation and complete closure, clean with mild detergent or solvent, secure damper open with fusible link.

4) BREAKAWAY CONNECTIONS

- Transverse joints illustrated at right have always been approved as breakaway connections. SMACNA testing has also approved the following variations as breakaway connections.
- Standing ^MS^M joints can be applied with no. 10 sheetmetal screws (through joint and duct) subject to the following limitations: Maximum 2 screws in each side and in bottom joint. Transverse joints illustrated can be applied as top and bottom joints with Drive Slip - side joints in duct heights up to 20 inches.

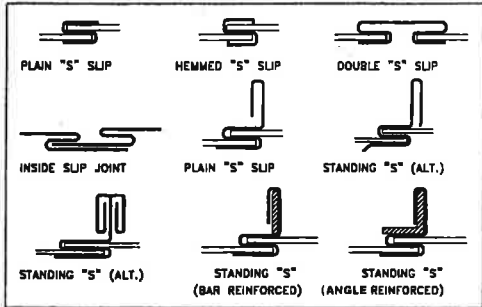

Round and Oval Duct Breakaway Connections

Round or flat oval ducts connected to type R, CR or CO damper collars may use no. 10 sheetmetal screws as follows:
 Ducts to 22" wide (or dia.) and smaller may use 3 screws.
 Ducts from 22" to and including 36" wide (or dia.) may use 5 screws.
NOTE: All breakaway connections described may have duct sealant applied in accordance with SMACNA recommendations. Sealant to be PA 2084 by Precision.

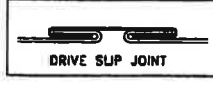

Manufactured Flanged System Breakaway Connections

Flanged connection systems manufactured by Ductmate, Ward, and Nexus are approved as breakaway connections when installed as illustrated.

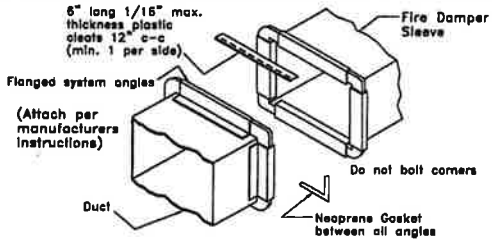

PROPRIETARY FLANGE SYSTEM BREAKAWAY CONNECTIONS

(TDC by Loekformer, TDF by Engle) TDC and TDF systems are approved as breakaway connections when installed as described in the TDC or TDF addendum to the SMACNA Duct construction Standards except the corners may not be bolted. Standard 6" metal clip may be used with spacing as shown in diagram.

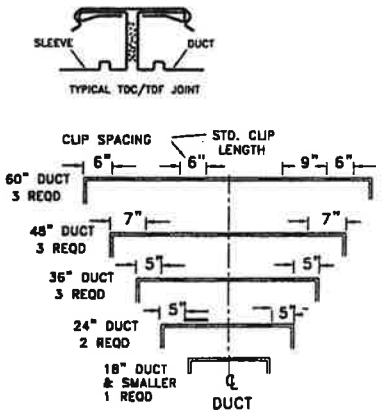

5) MULLION INSTALLATION INSTRUCTIONS FOR FIRE DAMPERS INSTALLED IN OVERSIZED WALL OPENINGS – STATIC SYSTEMS ONLY

These fabricated galvanized steel mullions are intended to subdivide a large vertical wall opening into smaller openings. These smaller openings are not to exceed the maximum size restrictions of the UL Classified 1-1/2 hour galvanized steel fire damper assembly.

CONDITIONS & RESTRICTIONS

Fabricated from galvanized steel with a normal yield strength of 42,000 psi. Intended for use in concrete block or poured walls only with a minimum wall thickness of 7" and a maximum wall thickness of 12". To permit proper embedding of anchors, hollow concrete block walls are to be filled at the opening by minimum 3,500 psi concrete. Steel mullions are not to be inside the ductwork. For ducted systems, each sub-divided opening must be individually ducted.

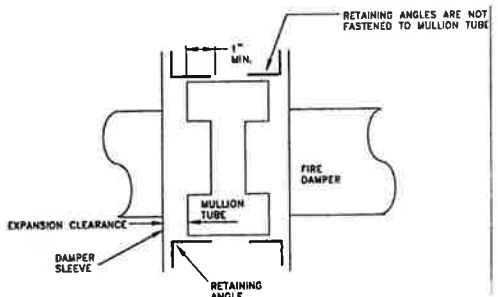
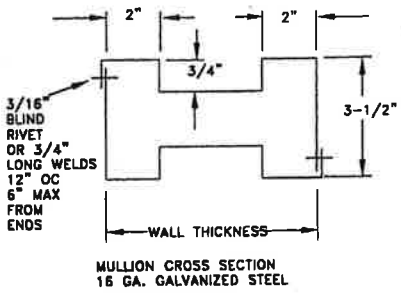
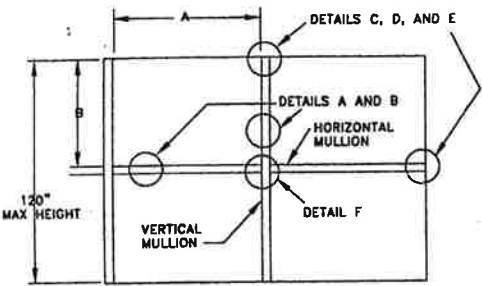

DETAIL B

Reference the damper's Installation instructions regarding the approved method of attaching the retaining angles to the sleeve, attaching the retaining angles to the sleeve, required expansion clearances, sleeve gauge etc.

"A" and "B" opening sizes are not to exceed the damper's approved maximum multiple assembly size. Vertical, horizontal, or vertical and horizontal mullions can be used, depending on the opening size.

DETAIL A

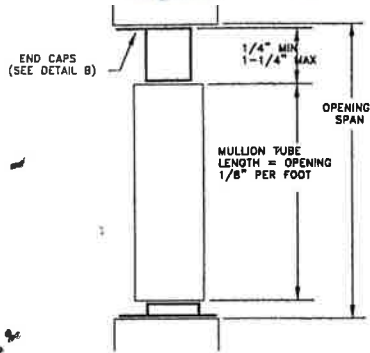

DETAIL C

The end caps are attached by means of 1" long x 3/8" dia. steel expansion anchors embedded into the opening with 1/4" dia. flat head machine screws. eight per end cap. If a steel lintel is used, four 1" long welds per end cap (two per leg) may be used.

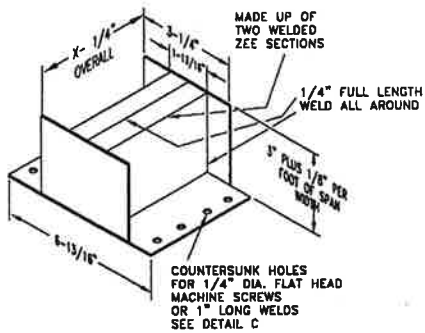

DETAIL D

Top, bottom or side end caps

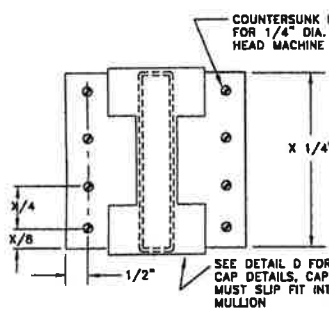

DETAIL E

All horizontal and vertical mullion tubes must be terminated with an end cap. These end caps may not be fastened to the mullion tube and must slide freely inside the mullion tube.

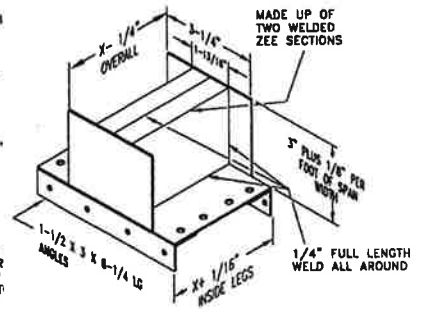

DETAIL F

Horizontal to vertical end cap 12 ga. galvanized steel. Attach the horizontal mullion end caps to the vertical mullion tube by means of (12) 3/16" dia. blind rivets or by 1/8" full length weld.

**6) SINGLE SIDED RETAINING ANGLE – INSTALLATION INSTRUCTIONS
VERTICAL OR HORIZONTAL MOUNT 1-1/2 HOUR RATING**

AMi Rapid Mounting/Angles "(For use on one sided angle installations)
These Instructions apply to 1-1/2 hour rated combination fire/smoke, smoke, static and dynamic curtain fire dampers mounted in masonry block, or metal, stud walls and concrete floors.

Angles to be 1-1/2" X 1-1/2" X 16 ga. for openings in metal stud, and concrete/ masonry walls and floors of 48 x36 and less. Mounting Angles are only required on one side of the wall or top of the floor, they must be attached to both the sleeve and the wall. Mounting angles may be installed directly to the metal stud under the wall board on metal installations only. Sizes larger will require the previous retaining angle design which consisted of 4 separate angles per side.

For one sided AMi Rapid Mounting Angle installations, the sleeve fasteners shall be no 10 sheet metal screws spaced 3" from each end and no greater than 12" on center. With a minimum of two(2) fasteners on each side, top and bottom. Wall/floor fasteners shall be no. 10 sheet metal screws 2" long, two screws on each side angle spaced 3 inches from each end; three screws on each head and sill angle with one screw in the center and one at each end spaced 3 inches from the ends.

Screw fasteners used in metal stud must engage the metal stud a minimum of 1/2"

Screw fasteners used in masonry walls or floors must engage the wall or floor a minimum of 2"

Angles should overlap the partition a minimum of 1" around the entire opening.

Installation per NFPA.90A, UL555, and SMACNA Fire Smoke and Radiation Installation Guide.

FASTENERS MUST BE PLACED WHERE THEY DO NOT INTERFERE WITH THE DAMPER OPERATION,

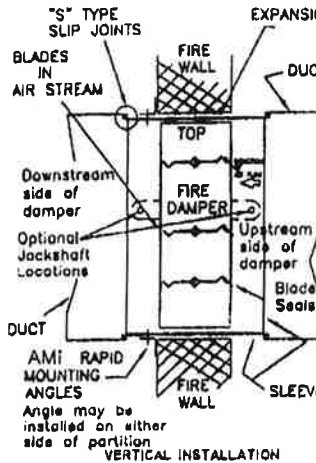

Angle may be installed on either side of partition
VERTICAL INSTALLATION

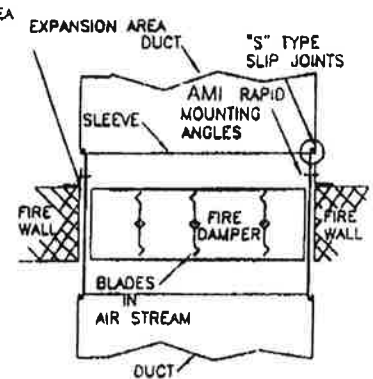

**HORIZONTAL INSTALLATION
AMi RAPID MOUNTING ANGLE
MUST BE INSTALLED ON TOP
OF FLOOR.**

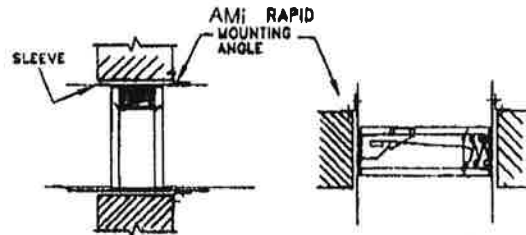

7) TRANSFER OPENING AND DUCT TERMINALS FOR 1-1/2 HOUR CURTAIN FIRE DAMPERS

**THIS INFORMATION APPLIES TO BOTH
THE AMI-75A AND AMI-75D DAMPERS**

1) Perimeter mounting angles to be 1-1/2 x 1-1/2 x 16 ga.

2) Grille to flange fasteners cannot penetrate the fire wall.

3) Secure angles to sleeve only, so as to frame the wall opening. Fasten to the sleeve only using the same means as required for fastening the damper to the sleeve.

4) Grille to flange attachment by means of 1/4" dia. pop rivets, #8 sheet metal screws or #8 bolts and nuts. Fasteners to be plated steel or stainless steel, minimum two fasteners per side

