



SUBMITTAL DRAWING
MD 200 S
STEEL MANUAL DAMPER

STANDARD CONSTRUCTION

MAXIMUM SIZE

Single section - 48"w x 48"h (1219 x 1219)

MINIMUM SIZE

6" w x 6" h (152 x 152)

BEARINGS

Bronze

FINISH

Mill galvanized

FRAME

18 ga. galvanized steel

LINKAGE

Concealed in frame for units over 36" (914) wide
X 12" (305) high

BLADE

22 GA. Galvanized

Unit supplied approximately 1/4" (6) smaller
than given duct dimensions.

Dimensions in brackets () indicate millimeters.

OPTIONS

Available at extra cost:
 Olite Bearings

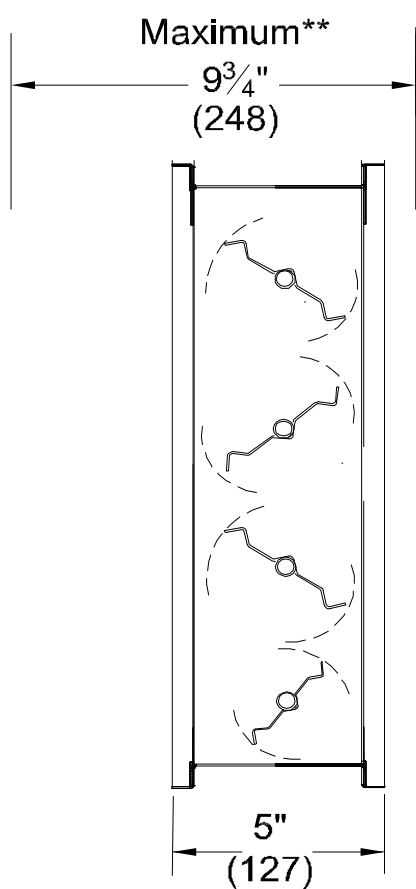

OPPOSED BLADE

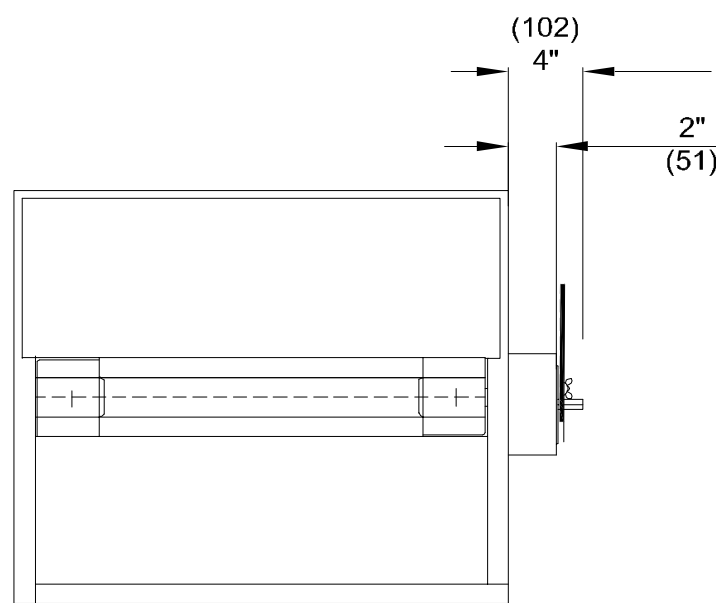

2" (51) hand quadrant
stand-off bracket
SINGLE BLADE
(UP TO 36" X 12")

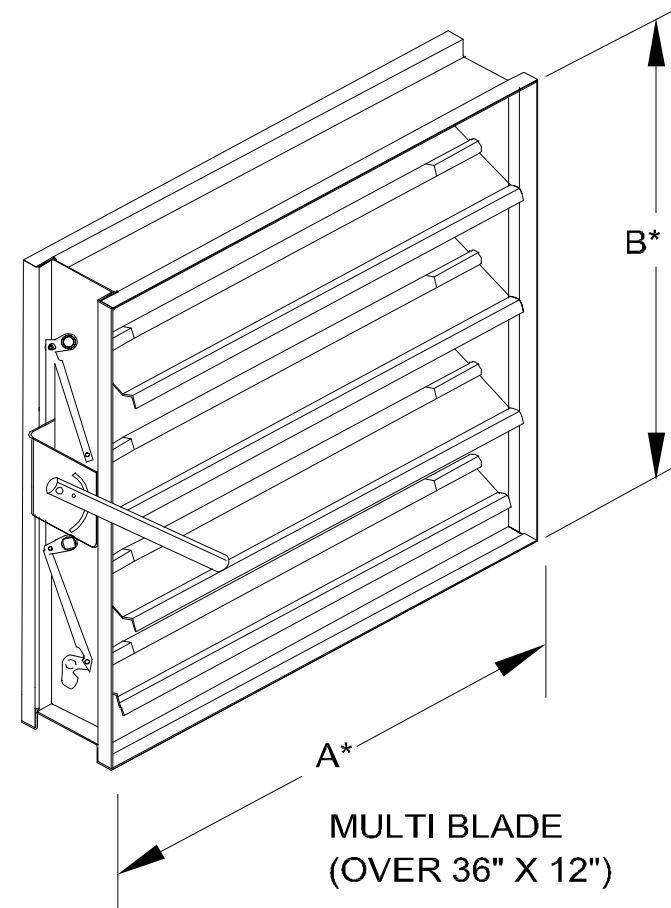

Project:
Location:
Architect
Engineer:

Contractor:
Address:
P.O. Number:
Date: